

Mepaco®

RELIABLE BY DESIGN



RELIABLE BY DESIGN

Reliability is the cornerstone that transcends our products and services. Great strides are taken to exceed expectations in production, quality, workmanship, longevity, safety, sanitary design and overall value. Reliability must be realized by all who come in contact with our products and services.

POSIFLO AUTOMATIC CHUB FEEDER

Delivering consistent volume and continuous, efficient flow to a variety of chub packing machines

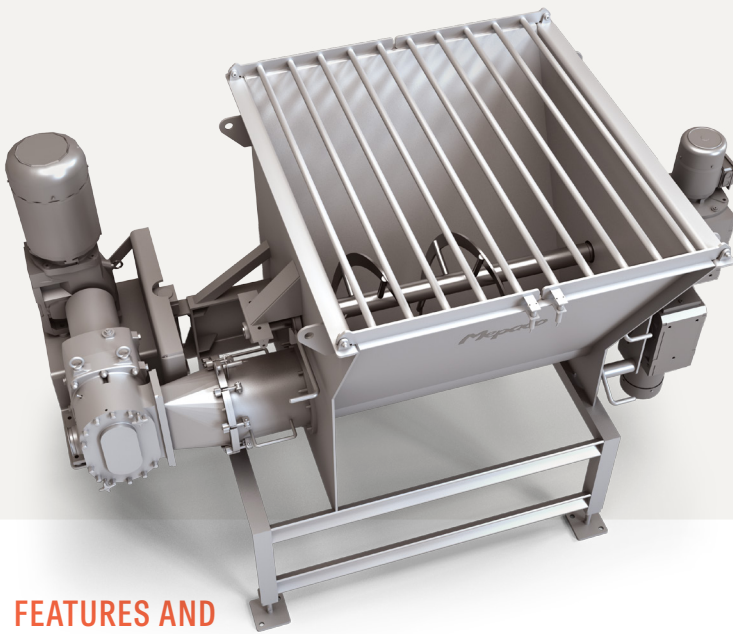

POSIFLO AUTOMATIC CHUB FEEDER

Introducing Mepaco's Versatile Chub Loading System

The PosiFlo Automatic Chub Feeder can be integrated with a variety of chub packaging systems. By providing a consistent volume and continuous, efficient flow; the PosiFlo delivers even pressures with limited shear and temperature rise. From the first chub to the last, product weights and quality are maintained throughout the batch. With optional pump sizes, the PosiFlo covers a broad range of production rates available to meet a variety of application challenges.

FEATURES AND BENEFITS

- Sanitary Design: Open Frame, stainless motors and pump
- Safety Grating: Eliminates the reach-in / fall-in hazard
- Finish: Electropolished food contact surfaces resist adhesion
- Pump Options: High and low capacity positive displacement
- Sanitary Seals: Quick release shaft seal for easy access
- Pump Mount: Swing away pump base for easy access
- Pump Transition: Inline orientation reduces smear and temperature rise
- Pressure Transducer: Provides automatic pressure sensing adjustment to ensure consistency
- Leveling Ribbon: Eliminates bridging and recycling of product
- PLC / VFD: Ensures proper speed coordination between feedscrew, pump and chub machine
- Ethernet: Handshaking with downstream equipment and remote troubleshooting capabilities

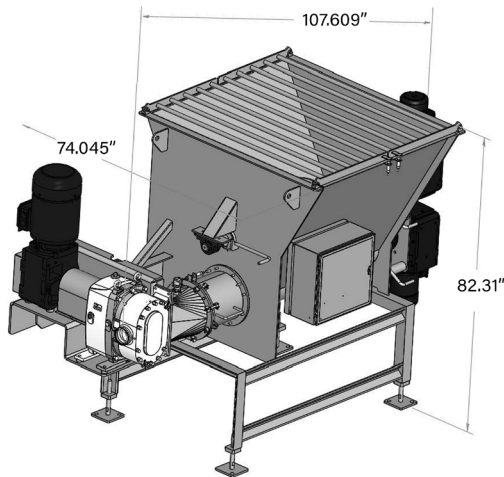

SPECIFICATIONS

CAPACITY	28 Ft ³ (-1400 Lbs @ 50 Lbs/Ft ³)
HOPPER DIMENSIONS	48" w x 56" d
SHAFT	12" diameter, full pitch auger
LEVELING RIBBON	19" diameter ribbon
PUMP DISCHARGE	Sanitary Bevel Seat in 2.5", 3" or 4"
DRIVES	Nord Gearmotors
FINISH	Bead blast exterior, electropolished product contact surfaces
PRODUCTION RATES	PF1: 2,000 - 7,500 Lbs/Hr (907 - 3,402 Kg/Hr) PF2: 7,500 - 15,000 Lbs/Hr (3,402 - 6,804 Kg/Hr) PF3: 15,000 - 36,000 Lbs/Hr (6,804 - 16,329 Kg/Hr)

CONTROLS

NEMA 4X SS Enclosure
Fused Disconnect, with Incoming Line Voltage Indication
SOLA 24VDC Power Supply
AB CompactLogix PLC
AB PanelView 10" HMI
AB PowerFlex 525 VFDs for Auger, Leveling Ribbon, Pump
AB GuardMaster Safety Relay and SensaGuard Switches
Programming Port, with 120VAC Outlet, on exterior of panel door
PLC and HMI options available, depending on the application
Secure Remote Connection is also available

Mepaco[®]

RELIABLE BY DESIGN

PART OF THE APACHE STAINLESS EQUIPMENT CORP. FAMILY

200 W. Industrial Drive
Beaver Dam, WI 53916 USA

Phone: 920-356-9900

www.mepaco.net



OSHA

PIP (Process Industry Practices)

ASME & API-650



SPECIALISTS IN: GRINDING & BLENDING | PUMPING & STUFFING | THERMAL PROCESSING | MATERIAL HANDLING | SYSTEM INTEGRATION